

HALOILA

缠膜机

OUR MISSION

We provide technological solutions and services to protect our customers' products.

Lifetime Commitment

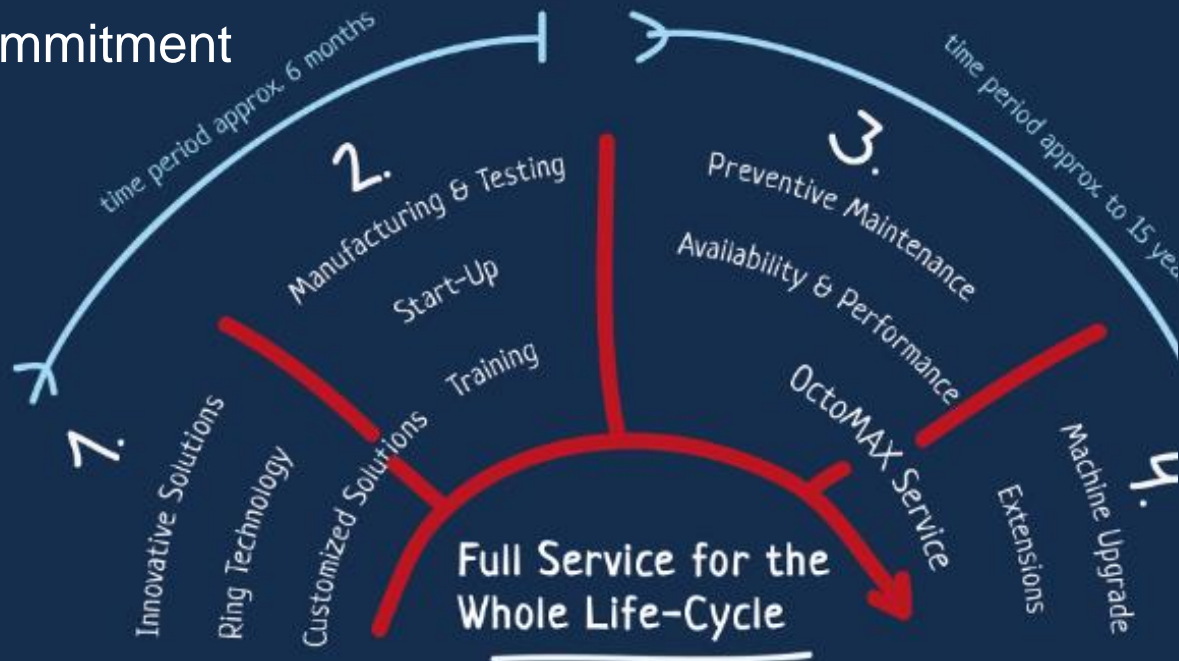

Our goal is to be a valued partner to our customers and partners as a global leader in the production and service of stretch packaging machines.

- Services are an integral part of our activities. They cover the entire life cycle of our products, from design, implementation, maintenance and upgrades to the design of a new product.
- Planning and start-up is short time period of total life cycle of machinery. Our strong knowledge and available tools to service customer through the machine life cycle is also benefit of our partners selling our equipment.

Automatic stretch solutions

Low & medium capacity range

<40 pph
20 rpm

<60 pph
25 rpm

<70 pph
35 rpm

WrapBOX

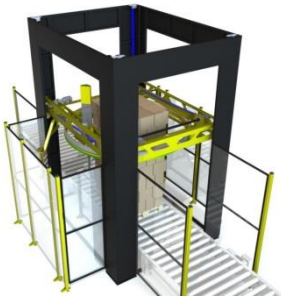

Octopus Compact



Octopus 1825B



Octopus 1835B



Octopus Compact 20
Octopus Compact TSi

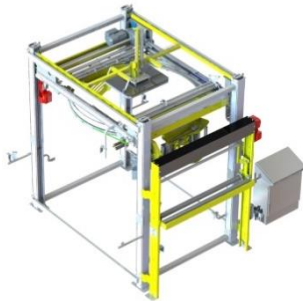

Automatic stretch solutions

High speed single head & Twin head range

<80 pph
45 rpm

Octopus 1845S



<90 pph
50 rpm

Octopus 1850T

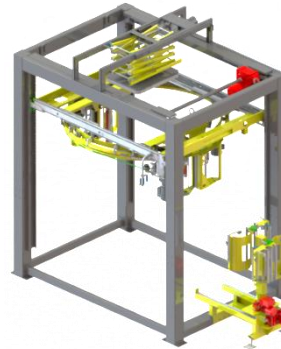

<135 pph
50 rpm

Octopus T200



<190 pph
70 rpm

Octopus 1845S SU



Automatic stretch solutions

Over size ring range

<55 pph
25 rpm

Octopus 2325S

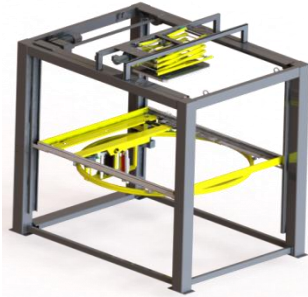

Octopus 2830S



<70 pph
35 rpm

Octopus 2335S

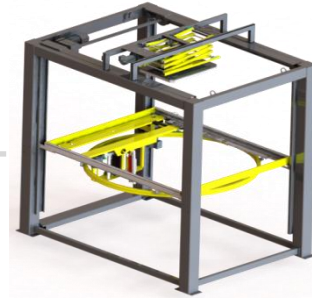

<120 pph
40 rpm

**Octopus 2340T
Octopus 2835T**

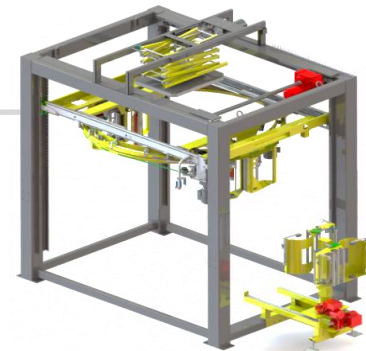

C-series.....	Aluminum frame entry level models
B-series.....	Aluminum frame models
S-series.....	Steel frame models
18XX-series.....	Max. load diagonal 1800mm (see detailed max. load dimensions from diagram)
23XX-series.....	Max. load diagonal 2300mm (see detailed max. load dimensions from diagram)
28XX-series.....	Max. load diagonal 2800mm (see detailed max. load dimensions from diagram)
XX45.....	Ring rotation speed (20...50rpm)
T200.....	Octopus model for over 200 pallets per hour
NT ²	No Touch No Tail stretch film seal & cut system
S-carriage.....	S-type film thread used in Octopus film carriages
Easy2Fix.....	Easy & safe film end fixing for new film reel loading
OctoFACE.....	User friendly HMI used in Octopus machines
AutoSPEED.....	Automatic wrapping capacity adjustment
Service screens.....	Proactive maintenance monitoring in OctoFACE HMI
OctoMAX.....	On line data acquisition (option)
Easy Load TS dispenser...	NEW Top sheet dispenser with easy & safe reel loading
Octop 1800.....	Separate top sheet dispenser for high demand & capacity applications (option)
OctoDROP.....	Separate Top sheet dispenser for variable load lengths (option)
RCS.....	Automatic reel change system (option)
CPD.....	Automatic corner post device (option)
Tail Tucker	Automatic film thread & cut instead of film seaming (option)
LogoWRAP.....	Solution for 4 side brand identification (option)
Stretch film roping.....	Film lower edge roping during bottom wraps (option)
FlexROPE.....	Automatic adjustable stretch film roping device (option)
BP-model.....	Brick & Pavement industry solution (option)
Air Flow kit.....	Dairy industry solution for shorter product cooling time (option)
HS conveyor kit.....	High Speed conveyor kit consisting infeed, wrapping zone and outfeed conveyors controlled by Octopus

OCTOPUS BENEFITS

More than 6500 machines in operation

Wide machine range for various customer demands

Product specified wrapping programs

World-wide distributor net

Integrated top sheet device with NEW easy reel loading technology

Easy to use and maintain

Reliable and well proven construction

Continuous lay-on force control by using wireless technology

World-wide known, high quality components

Wrapping can be started and stopped at any height

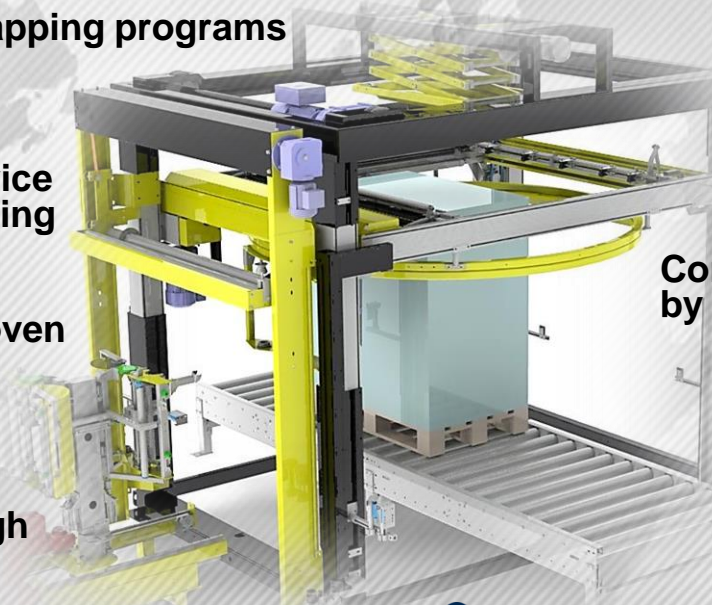

Octopus 
30 years of innovation

Original ring construction machine

Modular concept, machine can be updated afterwards with different options

Motorized Power-Pre-Stretch system with S-carriage

NT² No Touch No Tail film seaming - Reliable solution also for uneven pallet surfaces



Haloila ROCK

HALOILA

广州市镭诺智能技术有限公司

TEL: 020-8448 0821

Email: biz@lero.cn

www.leropack.cn